

Neda By* Libre Texting Business Plan

Neda Communications, Inc.

Document # PLPC-110019

June 15, 2009

Available on-line at:

<http://www.neda.com/PLPC/110019>

Contents

1	Executive Summary	2
2	Part of a Bigger Picture—Related Documents	2
3	Introduction	3
3.1	The Model	3
3.2	The Technology	3
4	Background and Objectives	4
4.1	Background	4
4.1.1	Requisite industry assets	4
4.1.2	The opportunity	6
5	Reviewer Assumptions	6
6	Making Libre Texting Widespread	7
6.1	Open and patent-free protocols	8
6.2	Free software for devices	9
6.3	Free software for MTAs (Message Transfer Agents)	9
6.4	Starting point Libre Texting service: part of ByStar services	9
7	Business Plan	9
7.1	Revenue sources	10
7.1.1	Software licensing (transient, tactical)	10
7.1.2	Professional and consulting services (transient, tactical)	10
7.1.3	Broad-based Libre Texting services (ultimate, strategic)	10
7.2	Path to commercialization	11
7.3	Competition: protocols, software, & services	12

List of Figures

1	Libre Texting: Parts	5
2	2007 Texting Numbers	10

1 Executive Summary

This business plan proposes Libre Texting: a new incarnation of the Mobile Email/Wireless Texting (henceforth “Texting”) medium, based on the Free Software ideology. Today the Texting industry is dominated by the proprietary, walled garden model. Libre Texting aims to provide equivalent functionality to existing proprietary Texting solutions such as BlackBerry, but (a) based entirely on patent-free protocols and free software, (b) using any mobile Internet device, (c) wherever any type of wireless Internet connectivity is available. The proposed approach comprises five elements: (1) the inherent propagative power of the Free Software and end-to-end models, (2) an overlay network architecture, (3) a new set of messaging protocols, (4) a novel software architecture for Message Transfer Agent integration, and (5) a new software architecture for multiform device integration, based on Device-Resident End-MTA middleware. The proposed technology is highly synergistic with current industry dynamics, including: burgeoning recognition of the power of FOSS, ready availability of Linux-based mobile devices, and widespread Wi-Fi availability. Existing email protocols lack push-mode delivery, and bandwidth and power efficiency; the proposed new protocol profile corrects these shortcomings. The proposed research is to determine feasibility of all critical elements of this approach at large scale.

The proposed Libre Texting technology is transformative, allowing the current walled-garden hegemony to be broken, and creating a new point of convergence as the standard. This has major engineering, business and societal consequences, with tangible benefits to the end-user. For example, greatly expanded range of choice—the user can now make independent selection of each component of her Texting setup, including the user interface, the Mail User Agent, the device, and other desired components (forwarders, synchronizers, filters). The Libre Texting technology unbundles the Texting application, opening every point of the Texting technology chain to competition and best-in-class component selection. Furthermore, the Libre model opens the Texting industry to the powerful free software generative dynamics. Businesswise, this Libre Texting initiative represents a radical shift of the Texting industry to the non-proprietary, for-profit quadrant, causing a major industry reconfiguration, with significant winners and losers. The losers are the existing vested proprietary interests, whose economic hegemony vanishes. But the winners are the many more companies who can now enter the Texting market—and the end-user who benefits from the resulting competition. Regarding broader societal consequences, the Libre model provides assurances of transparency, privacy and freedom of speech—assurances absent under the proprietary model.

2 Part of a Bigger Picture—Related Documents

The ByStar Libre Texting Business Plan is part of a bigger picture—it is a particular technological and business component within the much larger ByStar Libre Services initiative.

This document is one of a set of documents that together describe every aspect of the Libre Services initiative and the ByStar implementation. The following documents provide related information:

- *Libre Texting: A Collaborative Initiative and Reference Implementation.* The technical counterpart to the present Business Plan document. Describes Libre Texting from a conceptual and technical standpoint.

<http://www.neda.com/PLPC/110015>

- *Libre Services: A non-proprietary model for delivery of Internet services.* Describes the Libre Services conceptual model.
<http://www.freeprotocols.org/PLPC/100101>
- *The By* Concept: A Unified Model for Internet Services.* Describes the By* (pronounced “by-star”) implementation of the Libre model. This document also describes the growth dynamics of the Libre model in terms of service functionality, deployment, and usage.
<http://www.neda.com/PLPC/110001>
- *The By* Family of Libre Services: The future of the Internet Services industry.* Describes the business dimension, an essential component for real-world adoption of the Libre model. Makes the case for deployment of Libre Services in a commercial context.
<http://www.neda.com/StrategicVision/BusinessPlan>

3 Introduction

We are proposing a new incarnation of the Mobile Email/Wireless Texting medium (henceforth just “Texting”), based on the ideological principles of Free Software. We refer to this new incarnation as the **Libre Texting** model. Texting is already well established as a communications medium. But today the Texting industry exists in the form of a proprietary, walled-garden model, controlled by a small number of powerful proprietary commercial interests. The goal of the Libre Texting initiative is to provide equivalent functionality to existing proprietary Texting solutions such as BlackBerry, but:

- In a completely non-proprietary form
- Using *any* mobile Internet device
- Wherever *any* type of wireless Internet connectivity is available.
- At very large (planet-wide) scale

The strategy to accomplish this has two distinct parts: the “model” part, and the technology part.

3.1 The Model

The model part refers to the technocratic context within which the Texting functionality exists and is delivered. The proposed model is completely non-proprietary, or **Libre**. This means that the Texting service is based exclusively on patent-free protocols [3], implemented exclusively in free software, and conforms fully to the Internet end-to-end principle.

The upshot of all this is that the Libre Texting technology does not carry any restrictive limitations on its dissemination, implementation, or usage by anyone.

3.2 The Technology

The technology part consists of the technological innovations required for practical, large-scale implementation of Libre Texting. The critical enabling technology consists of the following four components, acting together in close integration:

- An Overlay Network architecture for end-to-end communication, permitting NAT traversal, and push.
- A new set of messaging protocols, providing push-mode delivery, wide-area narrowband efficiency, and scalability.

- A novel software architecture for smooth integration into existing Message Transfer Agents (MTAs). This is necessary for ready industry adoption and integration into multiple MTAs.
- A novel software architecture for uniform integration with multiple existing open platform devices and Mail User Agents. The proposed architecture is based on the concept of a Device-Resident End-MTA middleware module, as intermediary between the protocol software and the MUA.

Note that the Libre Texting initiative is not about new or enhanced messaging functionality. In terms of capability, Libre Texting provides essentially equivalent functionality to existing Mobile Messaging/Texting solutions such as the proprietary BlackBerry system. Rather, it is about a radically new model for ownership and delivery of this functionality.

Though the model is the critical basis for Libre Texting, it is not the subject of this project. As a starting-point assumption, we take the viability of the Libre model for granted. This research proposal is focused entirely on the above technology components. Specifically, the key focus of the research is to determine feasibility of these technology solutions at large scale.

To sum all this up, the proposal is *to determine feasibility of the critical technological components required for practical implementation of a complete Texting service, based on the Libre model, on a multiplicity of devices, and at very large (planet-wide) scale.*

This, of course, has immense business consequences. Should this proposal prove feasible, we plan to develop the business dimension to profit from our unique leadership role.

4 Background and Objectives

4.1 Background

The mobile messaging industry of today is a closed, proprietary construct. The wireless phone companies and/or their business partners own and control every component of the messaging service, including the device, the protocols, the software and the network.

In addition to their proprietary nature, existing wireless texting/messaging implementations (telephony SMS, and mobile email solutions such as BlackBerry) violate the Internet end-to-end principle by implementing centrally controlled, service provider store-and-forward components as a function “within” the network. This is in contrast to the Internet email architecture, which is end-to-end.

4.1.1 Requisite industry assets

Until quite recently, implementation of a Texting solution outside these walled-garden environments has been blocked by absence of the necessary non-proprietary components, such as open devices and public wireless spectrum. But now a completely non-proprietary, end-to-end Libre Texting solution is technically possible. This is enabled by a number of industry developments:

- Public spectrum Wi-Fi is now ubiquitous and has become the standard technology for final-leg device connectivity. In many locations Wi-Fi is available for direct, single-leg connectivity between the mobile device and the open Internet. This coverage can be expected to spread, eventually resulting in near-universal Wi-Fi Internet access.
- In situations or locations where direct Wi-Fi Internet connectivity is not available, a number of wide-area networks now exist to provide second-to-last-leg, wide-area wireless connectivity.
- Mature and sophisticated Linux-based PDAs are readily available as generic open mobile devices.
- Open, patent-free protocols exist for efficient wireless messaging. Also, device and server implementations of the protocols exist in the form of free software.

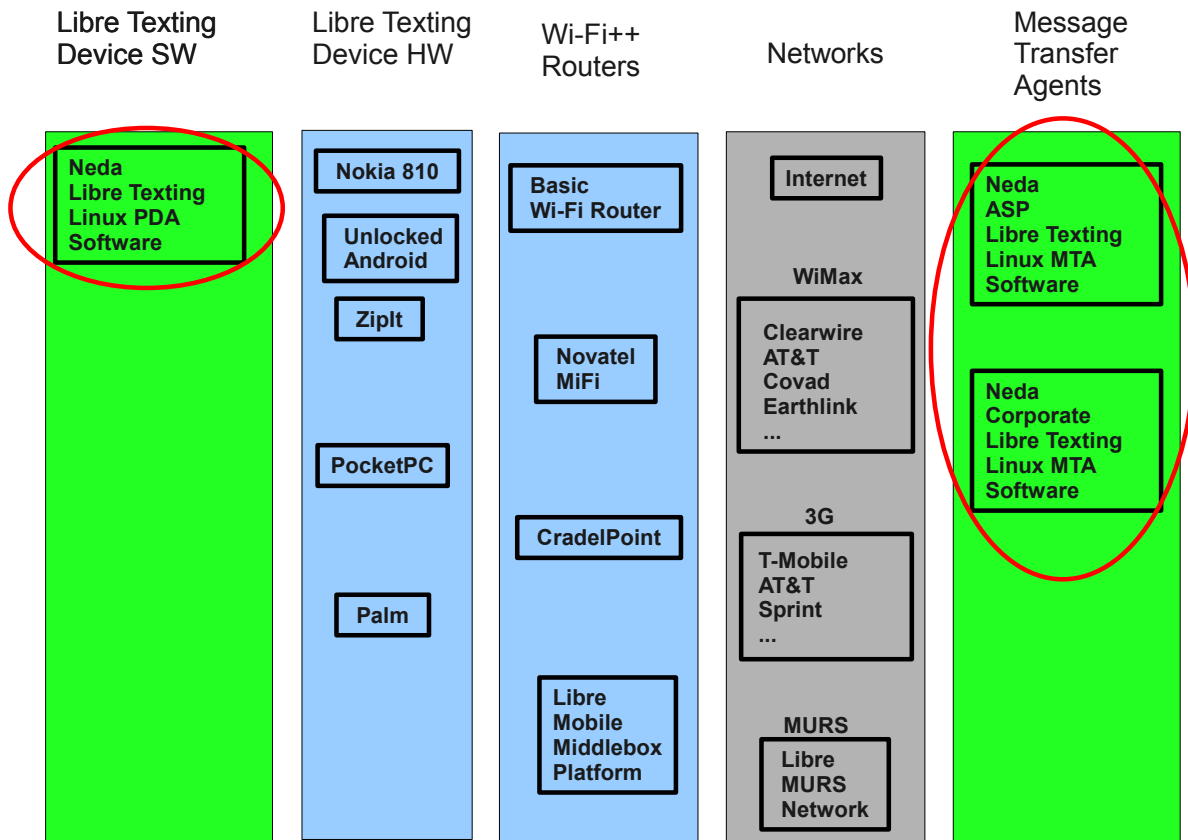

Figure 1: Libre Texting: Parts

- The eventual transition to IPv6 will allow restoration of the true mobile Internet end-to-end model, delivering mobile messaging capability without any form of built-in dependence on the service provider.

Thus all the necessary industry assets are now in place to implement a completely Libre Texting service. Every component of the service can be implemented in an open form, without any closed or proprietary or dependencies. This includes the device, the protocols, the software, and access to the wireless network.

4.1.2 The opportunity

The opportunity is now also in place.

The existing Texting/Mobile-Email industry is dysfunctional and unstable in a number of respects. First, the industry is severely fragmented. In 2009 there are five major mobile messaging players: BlackBerry, AT&T + Apple iPhone, Sprint + Palm Pre, T-Mobile + Google Android, and Microsoft PocketPC. These all provide essentially the same functionality. Yet these are isolated islands of functionality, based on different devices, different protocols, and different Mail User Agents, none of which are cross-compatible. A systems integrator or user cannot mix and match among these components. As additional industry players attempt to muscle their way into the lucrative Texting market, all indications are that this fragmentation will increase.

In the long term, this situation is untenable. As a global communications medium, there are strong forces of convergence towards a single dominant solution. Sooner or later the industry must and will coalesce around a unified Texting solution, providing across-the-board, industry-wide standardization.

In addition, there are strong strategic forces at work for change within the industry. Today the industry is a proprietary hegemony, from which small business players are excluded. Also excluded are some very large players, exceedingly covetous of the gigantic Texting market. Thus there is great pressure to break the walled-garden regime, by powerful forces outside the walled garden.

Given all this, a major industry shift of some sort is inevitable. Whether acting individually or in concert, there is strong motivation among the industry players to preemptively fabricate, and lay claim to, the elusive point of convergence. The preemptive fabrications may take many forms, but are likely to be quasi-Libre constructs, superficially resembling the true Libre solution we propose.

We believe that the Libre Texting model is ideally constituted to emerge as the decisive point of stability and convergence. In contrast to the existing proprietary incumbents, and any quasi-Libre upstart, Libre Texting is not constrained by any form of proprietary ownership mechanism such as patents or restrictive copyright. This is the fundamental generative power of the free/Libre model. It is this power that can cause Libre Texting to displace the existing proprietary regime, in the face of ferocious attempts by very powerful vested interests to defeat it in favor of the status quo.

Our goal is to establish Libre Texting as the convergence point and common standard for operation of all devices, and all message transfer services, worldwide. We believe Libre Texting is the right solution at the right time. The inherent generative power of the Libre model, together with the current industry instabilities, together with the four enabling technological innovations we describe, together with sophisticated engineering and business execution—all this can destroy the existing proprietary regime completely, preemptively stifle any quasi-Libre hijack attempt, and establish Libre Texting as the new industry standard.

The long-term forces towards convergence dictate an ultimate, winner-takes-all scenario. That winner can be us.

5 Reviewer Assumptions

We assume appropriate background knowledge on the part of the reviewers. In particular, we assume:

- An understanding of the fundamental dynamics of large-scale, protocol-based industries such as email and texting. In particular, an understanding of the very strong forces of convergence towards a unified

set of protocols for industry-wide interoperability.

- An understanding of the tremendous power of the non-proprietary model, as exemplified by free software and other non-proprietary constructs.
- An understanding of the particular mechanisms of business operation in the *non-proprietary, for-profit* quadrant. Note that the Venture Capitalist philosophy and belief system is fully wedded to proprietary ownership of assets as a fundamental business paradigm. This belief system is in total conflict with the notion of a non-proprietary business construct.
- An understanding of the walled garden model and its characteristics. In particular, an understanding of the characteristics of the existing, closed and proprietary wireless service provider model. These include a stifling of engineering creativity, a distortion of the competitive business environment, and perhaps most important, a hazard to basic civil liberties such as privacy, freedom of information, and freedom of speech.

And so conversely, an understanding of the essential societal benefits of replacing the proprietary walled garden model with the non-proprietary end-to-end model.

All these are critical underpinning concepts, essential for proper understanding of this proposal. In addition there is of course also the need for domain-specific knowledge of Mobile Messaging, Internet Email Protocols, and GNU/Linux software architecture.

6 Making Libre Texting Widespread

The Libre Texting model can be thought of as comprising two distinct elements: the adoption component, and the commercialization component. The adoption component is about making Libre Texting widespread. The commercialization component is about profiting from this. In this section we discuss the adoption dynamics; in the next section we discuss the commercialization mechanisms.

An essential component of the Libre Texting model is the logic and dynamics of how it will become widespread.

Today's mobile messaging landscape consists of ferocious competition among a multiplicity of solutions, all residing wholly within the confines of the proprietary ideological context.

Our proposal stands separate and distinct from all that. In terms of functionality, Libre Texting provides nothing new. It does not fall in the address-a-functional-need category. It provides the same functionality, but under a model that is vastly more potent than the proprietary model. This potency rests ultimately on the tremendous propagatory power of the non-proprietary model, which *removes all barriers and frictions from development, deployment, and usage at every point within the messaging framework.*

Every element of the Libre Texting model—the protocol design, the proposed software architecture, and the service delivery model—has been designed with a critical goal in mind: to enable its widespread propagation. Libre Texting has been endowed with all the necessary characteristics for it to emerge as the global Mobile Messaging industry standard, in use planet-wide, to the exclusion of all proprietary messaging solutions. The key dynamics to achieve this are:

- Eliminate all restrictions to deployment, participation and usage of Libre Texting at each point within the mobile messaging technology chain. The Libre Texting solution must spin within a frictionless bearing.
- Make the Libre Texting solution fully compatible with the existing messaging infrastructure.

Libre Texting includes the following components to achieve this:

- Completely open and patent-free protocols

- Free software for devices
- Free software for MTAs (Message Transfer Agents)
- A network architecture compatible with the existing messaging infrastructure
- An initial, in-place, easy-to-enroll Libre Texting service

6.1 Open and patent-free protocols

The Libre Texting protocols are patent-free, so there are no restrictions on their deployment and usage by anyone. Any company, organization or individual can implement the protocols without incurring licensing fees or other financial obligation.

As well as being patent-free, the Libre Texting protocols are also totally unrestricted. They have been published as Internet RFCs, thus ensuring that they remain freely and permanently available within the public domain.

Historical precedents

All this is in accord with the fundamental dynamics and history of the data communications industry. The Libre Texting proposal exists within a particular historical context. And part of this context is a number of historical industry events, that are essential to understanding the how's and why's of Libre Texting.

A particularly apposite historical event is the evolution of email, and the dynamics of that evolution. In 1992 or thereabouts, the then-fragmented email industry began to converge on a set of non-proprietary protocols. At that time the email landscape was dominated by a number of large proprietary players, most notably IBM's PROFS system, DEC's All-in-One, Lotus Notes, Microsoft Mail and various X.400 products. All proprietary, and all component-wise non-interoperable. These were able to interconnect through various gateways, but the fragmentary, proprietary, competitive and non-interoperable industry landscape proved fatal. In a matter of two years or so, all email solutions converged on SMTP/POP/IMAP, and all proprietary solutions disappeared. The convergence point was non-proprietary, and it was not driven by big business. SMTP (Internet email) provided no new capabilities and met no new need. But it reshaped the email medium. Note the word: reshaped. Internet email is now the global electronic mail standard, in use planet-wide, to the exclusion of all other electronic mail solutions.

Today we are presented with a a starkly equivalent landscape in the mobile messaging arena, and precisely the same fundamental dynamics are at work. We have SMS, Blackberry, Apple's iPhone mobile email, Palm, and multiple others. All proprietary, and all component-wise non-interoperable. As in 1992, these are able to interconnect through various gateways. But the fragmentary, proprietary, competitive and non-interoperable mobile messaging landscape is as fatal today as the wired messaging landscape was in 1992, and for exactly the same reasons.

This and other historical events are part of a pattern, which is itself a manifestation of a set of dynamics that have repeatedly driven convergence of major data communication services towards a unified protocol. These forces of convergence lead to a winner-takes-all dynamic, just like SMTP/POP/IMAP, as the service matures.

We have studied the history and characteristics of succesful protocols, and we understand it. And we have created the Libre Texting model based on that understanding. In 2000 we wrote a white paper titled "Lessons from History: Comparative Protocol Case Studies," [2], where we identify and analyse the critical enabling characteristics of convergence-point protocols.

In 2008, the IAB (Internet Architecture Board) published RFC-5218, [11], titled, "What Makes for a Successful Protocol?" The IAB document essentially repeats the same material we wrote in our 2000 paper.

Knowledge of the historical context and an intuitive understanding of the underlying dynamics is a prerequisite for understanding the logic and viability of Libre Texting. A reviewer without this understanding is not qualified to assess this proposal.

Our proposal is about convergence on a set of non-proprietary end-to-end protocols for mobile messaging, in precise analogy with the 1992 history. The proposed convergence point is non-proprietary, and creates a gigantic business opportunity for those shaping the convergence.

6.2 Free software for devices

Implementation of Libre Texting at the device end is based on a Device-Resident End-MTA architecture. This is an important component of our design-for-propagation principle. This architecture allows Libre Texting capability to be implemented as a straightforward add-on to existing Mail User Agents (MUAs). There is no disruption to the existing MUA landscape at all, so that best-of-breed MUAs can be used for Libre Texting without no modification.

The Device-Resident End-MTA package resulting from this proposal is quite general, and can be installed in all Linux PDA platforms, and very likely other platforms as well.

6.3 Free software for MTAs (Message Transfer Agents)

The same design-for-propagation principle applies at the message center end. The software architecture for integration of Libre Texting into existing Message Transfer Agents (MTAs) involves inclusion of minimal new software, allowing straightforward integration of Libre Texting into the existing messaging infrastructure.

The Libre Texting MTA package resulting from this proposal is also quite general, and immediately applicable to many existing mail servers.

6.4 Starting point Libre Texting service: part of ByStar services

The final piece required for widespread usage is an initial service to deliver Libre Texting functionality to the end user. We have our own service in place to address this requirement: the ByStar family of services [4], providing Libre Texting as a standard feature. As part of our strategy to promote unrestricted and widespread usage of the service, the ByStar services will initially be deployed under a no-cost model.

The ByStar services are in fact much broader in scope than mobile messaging, providing a comprehensive set of services for individuals and businesses. In particular they provide Libre Texting as part of an integrated suite of messaging capabilities, providing various messaging forms and access methods, both wired and mobile. Hereafter we will call the messaging component of ByStar the **ByStar Libre Texting service**.

7 Business Plan

Libre Texting represents a radical shift of the Texting industry to the *non-proprietary, for-profit quadrant*, causing a major industry reconfiguration, with significant winners and losers. The losers are the existing vested proprietary interests, whose economic hegemony vanishes. But the winners are the many more companies who can now enter the Texting market—and the end-user who benefits from the resulting competition.

Clearly, the commercial potential of this is immense, and certainly not limited to Neda. This can impact, positively, thousands of jobs throughout the industry.

We have already formulated a coherent business plan for our own participation. Deployment of our broad-based Libre Texting services will take place within the context of our existing ByStar Libre Services

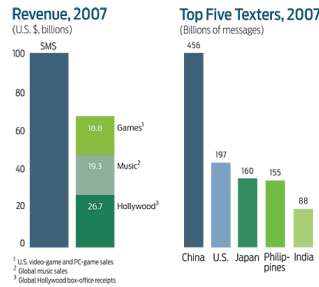

Figure 2: 2007 Texting Numbers

[4], as part of the existing ByStar Business Plan [5]. This is an Open Business Plan that specifically addresses the dynamics and mechanisms of business operation within the *non-proprietary, for-profit quadrant*.

As an established communications modality, the magnitude of the Texting market is already well characterized. For example see the article titled *thx 4 the revnu* by Steven Cherry in the October 2008 issue of IEEE Spectrum, available at: <http://www.spectrum.ieee.org/oct08/6817>. This article provides relevant analysis and statistics on Texting usage and market size.

In 2008 the Texting/Mobile Email market was over \$150 billion dollars. Putting this in the context of a \$150k funding, we see that the market size is about one million times greater than that initial funding. Furthermore, the texting market is a recurring revenue market.

Figure 2 shows the top five texters in 2007 (Sources: Ovum, Quantifica). The growth of texting usage in the U.S. and world wide is not showing any slowdowns

7.1 Revenue sources

Our major revenue streams are described in the following sections. The first two are transient and tactical in nature. The third is the truly enormous business opportunity, and our ultimate strategic goal.

7.1.1 Software licensing (transient, tactical)

We will develop a complete set of Libre Texting software based on two sets of licenses: (1) Free Software Licenses, and (2) Neda Professional Software Licenses.

This dual licensing strategy is well established in the open-source arena. From a business perspective, the Gnu General Public License (GPL) is very restrictive. The GPL generally bars usage under the proprietary model, thus creating a demand for Neda Professional Software Licenses.

7.1.2 Professional and consulting services (transient, tactical)

We anticipate that our Software Licensing revenues will be accompanied by Systems Integration consulting revenues. Neda has a long track record in the Consulting and Systems Integration arena.

7.1.3 Broad-based Libre Texting services (ultimate, strategic)

The ultimate long-term revenue source is of course the Libre Texting services business itself. Our unique leadership role gives us a number of advantages in this arena including: (a) first-mover position in the Libre

Texting industry, (b) name recognition as the leader of this initiative, and (c) a highly favorable marketing opportunity in the form of Libre vs Proprietary ideological conflict.

The assets we have built over the past several years, in particular our Data Center and our existing Internet Application Services, leaves us well positioned to realistically target becoming a large-scale Libre Texting service provider.

7.2 Path to commercialization

The proportions of revenues deriving from the three major sources above will shift radically over time. Initially, the majority of Neda's revenues will derive from software licensing and professional services. Though we will provide support for Libre Texting services from the beginning, we do not expect this to be a significant revenue source at the outset.

However, as the industry matures, support for the Libre Texting service (and beyond that, the broader ByStar services) will emerge as the dominant revenue stream, and will eventually eclipse all others. The Libre Texting and ByStar segment of the industry represents the ultimate, major, profit-making opportunity for Neda. The path to commercialization consists of the following steps:

Making Libre Texting widespread (Linux PDAs): We have previously described the general principles of our strategy for making Libre Texting widespread. The execution steps for specific device platforms and operating systems include:

- Include device-side Libre Texting software as available with the following distributions: Maemo 5, Maemo 4, Ubuntu, Debian (and perhaps Android). Note that Maemo 5, Maemo 4, Ubuntu and Debian all use the .deb packaging, and that standard entry into the Debian distribution propagates to other distributions.
- Include MTA Libre Texting software as available with the following distributions: Debian, Ubuntu, Redhat, Centos.
- Promote and support usage among the following MID/phone/netbook communities: Nokia n900, Nokia n810, Android, Asus, and other Debian/Ubuntu based netbooks.
- Support ByStar Libre Texting for the above. Note that standard entry into the distribution of device-side Libre Texting software directs usage towards our ByStar Libre Texting service by default.

This stage of execution generates minimal revenues. However the incremental cost of building and maintaining these software products and services is minimal for Neda—we have much of this in place already.

Note that because of our non-proprietary model, we do not need to partner with any existing players to initiate and promote Libre Texting usage.

Support for ISP/ASP deployment (professional services, plus hosting revenues): Once usage of Linux Mobile Internet Devices for Libre Texting is well established, we will promote inclusion of Libre Texting into existing services of ISPs and ASPs. Details of our business development strategy in this arena is presented in a separate document [6].

Our revenue sources at this stage will consist of consulting services involved in deploying Libre Texting services within the ISP and ASP operating environment. In certain cases we may host the service for ISPs/ASP in our data center, providing hosting as a further revenue source for us.

Software for proprietary devices (licensing, plus professional services): Once usage of GNU/Linux Mobile Internet Devices for Libre Texting is well established and multiple Libre Texting service providers are in place, we will next focus on enabling Libre Texting implementation on devices with proprietary operating systems.

Devices based on proprietary operating systems such as Windows CE, iPhone, Palm OS, Epoc, etc. provide a licensing revenue source for Neda since they cannot use the General Public License. For these devices we offer commercial Neda Professional Software Licenses. This Software Licensing revenue source will typically be accompanied by revenues from systems integration and other professional services.

Subscription-based, ByStar Libre Texting services: As usage of our ByStar Libre Texting services grows, more of our revenues will be based on recurring subscription service usage model. In terms of revenue characteristics, this is similar to RIM's Blackberry model. This is an ultimate, strategic revenue source.

Advertizing-based ByStar Libre Texting services: As our Libre device software becomes increasingly widespread and reaches larger scale, it then becomes cost-effective to point users by default to the advertizing supported branch of ByStar Libre Texting Services. In terms of revenue characteristics, this is similar to Microsoft's hotmail service.

7.3 Competition: protocols, software, & services

The nature of competition within the Libre context is very different from the proprietary context.

Within the Libre context, it is not possible to maintain sustainable advantage on the basis of proprietary ownership, nor is it possible to create advantage on the basis of functional service differentiation from any other Libre Texting service provider. Any technical enhancement becomes instantly available to all providers throughout the entire Libre environment.

Instead, competition within the Libre environment becomes a matter of which protocols, software implementations and services are used to implement and deliver the service.

With regard to protocols/profiles, we recognize Lemonade (RFC-4550) [10] [9] [7] and Push-IMAP ([8] plus its internet-draft) as potential alternatives to EMSD. However, we believe that the efficiency characteristics of EMSD [1], which are not matched by these IETF-proposed protocols, will prove decisive. The efficiency of EMSD is better suited to Libre Texting, particularly in the case of narrowband wide-area networks.

With regard to free software protocol implementations, alternative and/or overlapping software capabilities are inherently non-competitive, and freely available for integration in our own Neda Libre Texting implementation. Furthermore, our own implementations are accompanied by a coherent business model, which is not the case for most other FOSS projects.

With regard to Application Service Providers (ASPs), we expect that large proprietary services such as Google, MSN and Yahoo will be reluctant and slow to adopt the Libre Texting model, because of their existing business relationships and investment in proprietary solutions.

References Cited

- [1] "Mohsen BANAN". "emsd efficiency". Permanent Libre Published Content "100003", Libre Content, "October" 1996. <http://www.freeprotocols.org/PLPC/100003>.
- [2] Andrew Hammoude "Mohsen BANAN. "lessons from history: Comparative case studies". Permanent Libre Published Content "100017", Libre Content, "August" 2000. <http://www.freeprotocols.org/PLPC/100017>.
- [3] Andrew Hammoude "Mohsen BANAN. "the free protocols foundation policies and procedures". Permanent Libre Published Content "100201", Libre Content, "March" 2000. <http://www.freeprotocols.org/PLPC/100201>.

- [4] Andrew Hammoude " " Mohsen BANAN. " the by* concept: A unified model for internet services ". Permanent Libre Published Content "110001", Libre Content, "January" 2007. <http://www.neda.com/PLPC/110001>.
- [5] Andrew Hammoude " " Neda Communications, Inc. " the by* family of libre services: The future of the internet services industry an open business plan ". Permanent Libre Published Content "110002", Libre Content, "March" 2009. <http://www.neda.com/StrategicVision/BusinessPlan>.
- [6] Mohsen BANAN Andrew Hammoude " " Neda Communications, Inc. " the by * family of libre services for network service providers: Generic proposal a strategy for rapid entry into the internet application services market a proposal ". Permanent Libre Published Content "110005", Libre Content, "September" 2007. <http://www.neda.com/PLPC/110005>.
- [7] E. Burger and G. Parsons. LEMONADE Architecture - Supporting Open Mobile Alliance (OMA) Mobile Email (MEM) Using Internet Mail. RFC 5442 (Informational), March 2009.
- [8] M. Crispin. INTERNET MESSAGE ACCESS PROTOCOL - VERSION 4rev1. RFC 3501 (Proposed Standard), March 2003. Updated by RFCs 4466, 4469, 4551, 5032, 5182.
- [9] R. Gellens. Deployment Considerations for Lemonade-Compliant Mobile Email. RFC 5383 (Best Current Practice), October 2008.
- [10] S. Maes and A. Melnikov. Internet Email to Support Diverse Service Environments (Lemonade) Profile. RFC 4550 (Proposed Standard), June 2006.
- [11] D. Thaler and B. Aboba. What Makes For a Successful Protocol? RFC 5218 (Informational), July 2008.